



# GreenSpace Surface-mounted

## SM291C LED10/830 PSU WH GM

Power supply unit - High-gloss mirror - Reflector - 90° -

Philips GreenSpace Surface-mounted LED Downlight delivers a superior LED alternative that's up to 66% more energy efficient than the conventional downlight retrofits. Blending seamlessly into its environment, GreenSpace Surface-mounted LED Downlight mimics the form of conventional recessed downlights minus the associated high energy and maintenance costs.; Philips GreenSpace Surface-mounted LED Downlight is also ideal for all commercial lighting applications as well as public indoor space where there is limited space in the ceiling.

### Product data

General information		Flammability mark	
Beam angle of light source	- °	CE mark	-
Light source color	830 warm white	ENEC mark	-
Light source replaceable	No	Warranty period	3 years
Number of gear units	1 unit	Constant light output	No
Driver/power unit/transformer	Power supply unit	Number of products on MCB of 16 A type B	30
Driver included	Yes	EU RoHS compliant	No
Optic type	High-gloss mirror	Light source engine type	LED
Optical cover/lens type	Reflector	Service tag	Yes
Luminaire light beam spread	90°	<b>Operating and electrical</b>	
Control interface	-	Input Voltage	220 to 240 V
Connection	-	Input Frequency	50 or 60 Hz
Cable	-	Inrush current	11 A
Protection class IEC	Safety class I	Inrush time	0.003 ms
Glow-wire test	Temperature 750 °C, duration 5 s		

## GreenSpace Surface-mounted

Power Factor (Min)	0.9
<b>Controls and dimming</b>	
Dimmable	No
<b>Mechanical and housing</b>	
Housing Material	Aluminum die cast
Reflector material	Aluminum
Optic material	Aluminum
Optical cover/lens material	-
Fixation material	-
Optical cover/lens finish	-
Overall length	0 mm
Overall width	0 mm
Overall height	135 mm
Overall diameter	160 mm
Color	White
<b>Approval and application</b>	
Ingress protection code	IP20 [ Finger-protected]
Mech. impact protection code	IK02 [ 0.2 J standard]
<b>Initial performance (IEC compliant)</b>	
Initial luminous flux (system flux)	1000 lm
Luminous flux tolerance	+/-10%
Initial LED luminaire efficacy	100 lm/W

Init. Corr. Color Temperature	3000 K
Init. Color Rendering Index	>80
Initial chromaticity	(0.44, 0.40) SDCM <5
Initial input power	10 W
Power consumption tolerance	+/-10%

### Over time performance (IEC compliant)

Median useful life L70B50	50000 h
Median useful life L80B50	40000 h
Median useful life L90B50	20000 h

### Application conditions

Ambient temperature range	-20 to +40 °C
Suitable for random switching	No

### Product data

Full product code	911401847199
Order product name	SM291C LED10/830 PSU WH GM
Order code	911401847199
Numerator - Quantity Per Pack	1
Numerator - Packs per outer box	1
Material Nr. (12NC)	911401847199
Net Weight (Piece)	0.599 kg



## Dimensional drawing

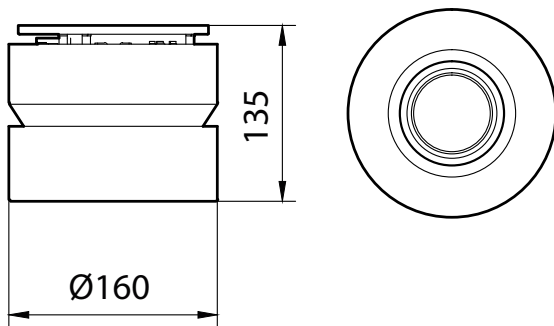

SM291C LED10/830 PSU WH GM

## GreenSpace Surface-mounted

