



Model: SLE-W1

SPECIFICATION:

- Input Voltage** : 220V+/-10%, 50/60Hz
- Mode of Operation** : Non - maintained
- Lamp** : 2 x 22 White SMD LED (≈ 2 X 3W)
- Safety Feature** : Over discharge and over charge protection
- Rated Duration** : 2 hours
- Power Consumption** : 3W
- Fitting Construction** : PC casing
- Mounting** : Wall mounting
- Diffuser** : Fire retardant cast PC
- Battery Type** : Ni-Cd
- Unit Dimension(mm)** : 306 X 135 X 86
- Compliance** : MS 983, IEC598-2-22

Weight(Kgs): 1.1



ENVIRONMENTALLY FRIENDLY

IP30

Benefits:

- High durability*
- No replace bulb*
- Easy Installation*
- Maintenance Free*
- Power saving 90%*

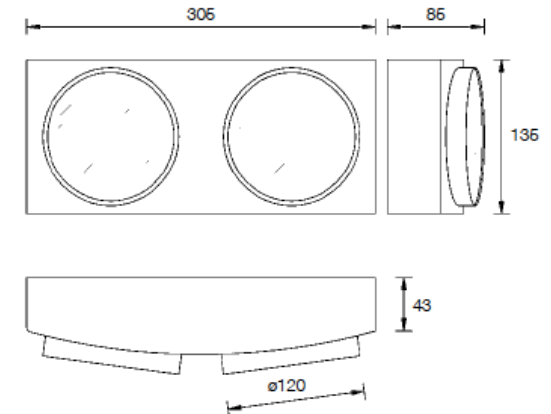

Note: Due to continuous development and improvement, our company reserve the right to change specification without notice