



weatherproof EMERGENCY LIGHT

Model: SLE-IP65

SPECIFICATION:

Input Voltage	: 220V+/-10%, 50/60Hz
Mode of Operation	: Combined Non-maintained or combined maintained
Lamp	: White SMD LED with lifespan 50,000 burning hours
Safety Feature	: Over discharge and over charge protection
Rated Duration	: 2, 3, 4 ... hours
Power Consumption	: 1.5W, 3W
Fitting Construction	: ABS or Polycarbonate
Mounting	: Wall, Ceiling, pendant
Diffuser	: Fire retardant cast PC
Battery Type	: Ni-Cd, Li-Ion(-40°C to +65°C)
Unit Dimension(mm)	: 350 X 120 X 75
Test	: Micro button or Wireless TEST by remote control (Optional)
Weight	: 0.85Kg
Compliance	: MS 983, IEC598-2-22



ENVIRONMENTALLY FRIENDLY

IP65

Benefits:

High durability

No replace bulb

Easy Installation

Maintenance Free

Power saving 90%

* SUPER SMALL

* SUPER BRIGHT

* SUPER THIN

* SUPER LIGHT

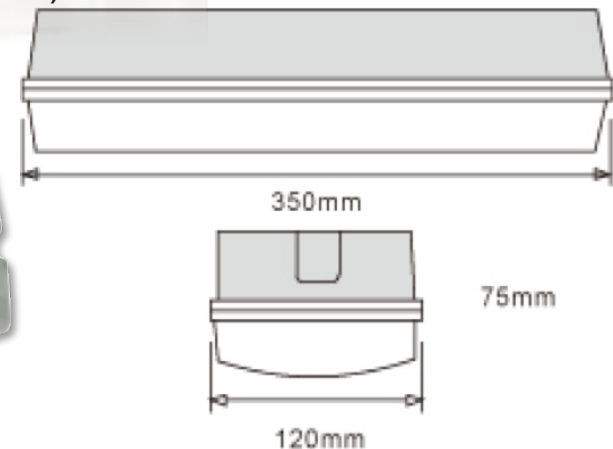

Note: Due to continuous development and improvement, our company reserve the right to change specification without notice