



GreenUp Magnetic Flex

ST307Z IECP

Retail & Hospitality has a clear trend that clusters of choices is one of the most important DNAs that being strongly expected in this specific applications. GreenUp Magnetic Flex is a comprehensive product family with magnetic design which supports an easier and flexible way of installation and commissioning. It offers a complete range of options with product diversity and control availability. GreenUp Magnetic Flex gives you a plenty of flexibility to create the lighting magics.

Product data

General information		Dimensions (Height x Width x Depth)	
Protection class IEC	-	18 x 19 x 143 mm	
CE mark	-	Approval and application	
Material	Aluminum	Ingress protection code	-
Angle	-	Mech. impact protection code	-
Accessory color	Black	Product data	
Operating and electrical		Order product name	ST307Z IECP
Input Voltage	- V	Order code	911401548132
Input Frequency	- Hz	Numerator - Quantity Per Pack	1
Mechanical and housing		Numerator - Packs per outer box	100
Overall length	143 mm	Material Nr. (12NC)	911401548132
Overall width	19 mm	Net Weight (Piece)	0.019 kg
Overall height	18 mm		
Overall diameter	143 mm		

GreenUp Magnetic Flex

Dimensional drawing

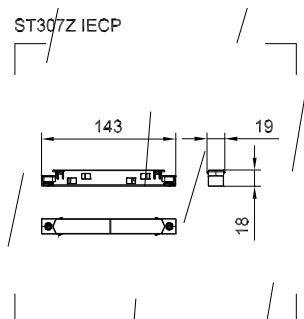

ST307Z IEC P

