



GreenUp Magnetic Flex

ST307Z SM L1000

Accessory - GreenUp Magnetic Flex

Retail & Hospitality has a clear trend that clusters of choices is one of the most important DNAs that being strongly expected in this specific applications. GreenUp Magnetic Flex is a comprehensive product family with magnetic design which supports an easier and flexible way of installation and commissioning. It offers a complete range of options with product diversity and control availability. GreenUp Magnetic Flex gives you a plenty of flexibility to create the lighting magics.

Product data

General information		Dimensions (Height x Width x Depth)	
Protection class IEC	-	53 x 27 x 1000 mm	
CE mark	-	Approval and application	
Material	Aluminum	Ingress protection code	-
Angle	-	Mech. impact protection code	-
Accessory color	Black	Product data	
Operating and electrical		Order product name	ST307Z SM L1000
Input Voltage	- V	Order code	911401559502
Input Frequency	- Hz	Numerator - Quantity Per Pack	1
Mechanical and housing		Numerator - Packs per outer box	10
Overall length	1000 mm	Material Nr. (12NC)	911401559502
Overall width	26.5 mm	Net Weight (Piece)	1.160 kg
Overall height	53 mm		
Overall diameter	1000 mm		

GreenUp Magnetic Flex

Dimensional drawing

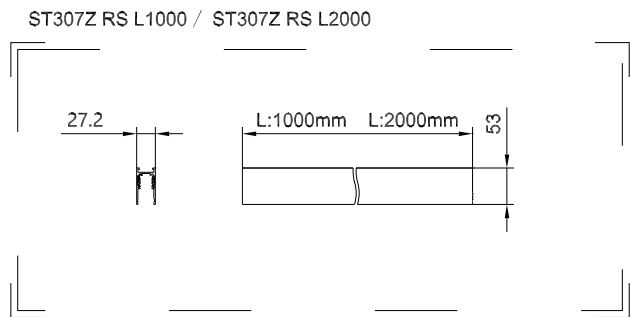

ST307Z SM L1000

